

Tools Required

① **Portable electric drill**

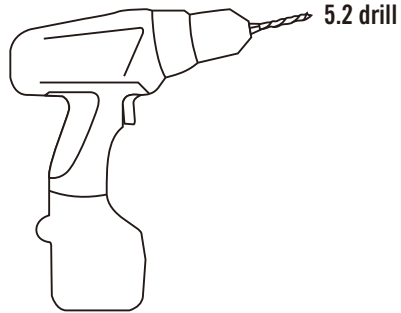

② **Pneumatic Rivet set**

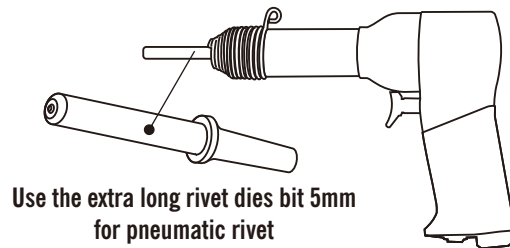

Assembly Process

1. Drill through all rivets on parts to be changed using a Portable Electric Drill ①
2. Replace the part to be changed & insert new rivets through from the outside of the flight case.
3. Insert supplied washers to rivets from the inside of flight case.
4. Using a pneumatic rivet gun ② secure all rivets onto the flight case ensuring the washer is well tightened.

Spare Parts Item

- U10180** UDG ball corner (for top case) + rivets
- U10181** UDG handle + rivets
- U10182** UDG butterfly latch + rivets
- U10183** UDG casing wheels set left & right + rivets
- U10184** UDG wheels set left & right + rivets
- U10185** UDG rubber foot
- U10186** UDG brace + rivets
- U10187** UDG Ultimate trolley flight case frame + rivets
- U10188** UDG industrial rivets and washer (one pack 25 pcs.)
- U10189** UDG ball corner (for bottom case) + rivets

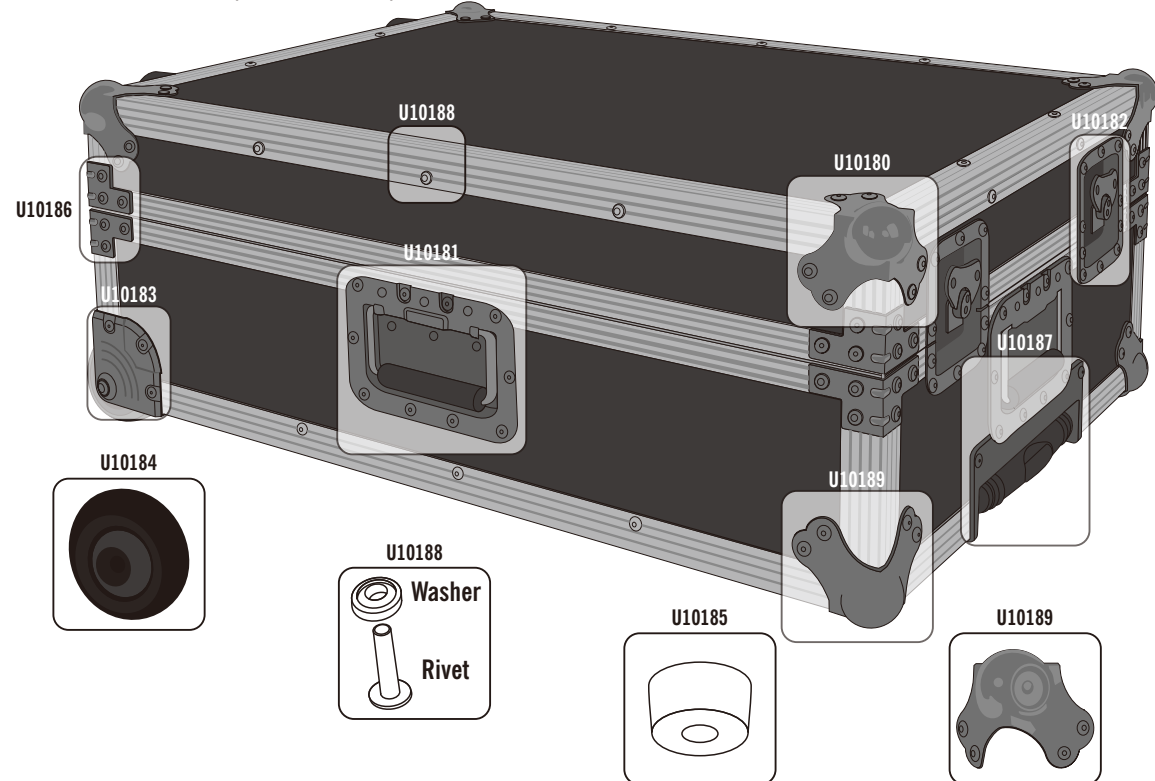

UDG[®]

© UDG USA Inc. All Rights Reserved
U.S. & Foreign patents pending
Made in China