

Tools required

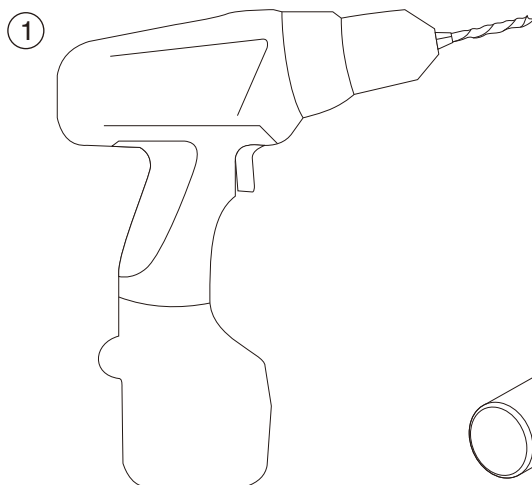

Portable electric drill

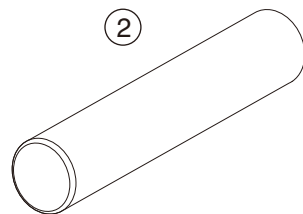

Metal pipe solid with $\varnothing 10\text{mm}$

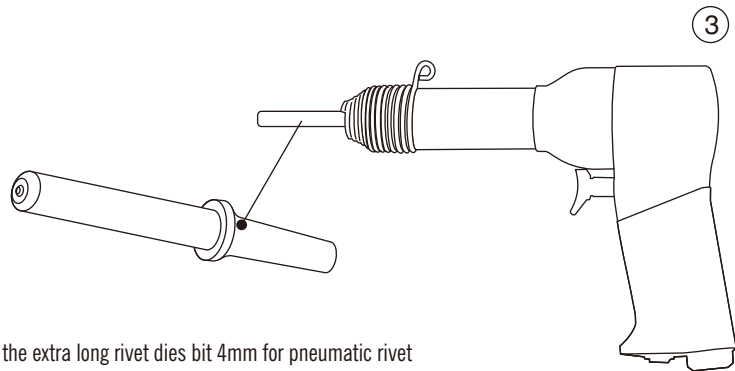

Use the extra long rivet dies bit 4mm for pneumatic rivet

Pneumatic Rivet set with Bucking Bars

	1 Set package spare part on section left	Rivet and Washer A short	Rivet and Washer B medium	Rivet and Washer C long
UDG Ultimate Slingbag Trolley Deluxe UDG Ultimate Slingbag Trolley Set Deluxe				
	1 Set package spare part on section right	Rivet and Washer A short	Rivet and Washer B medium	Rivet and Washer C long
UDG Ultimate Slingbag Trolley Deluxe UDG Ultimate Slingbag Trolley Set Deluxe				
	1 Set package spare part on section left	Rivet and Washer A short	Rivet and Washer B medium	Rivet and Washer C long
UDG Ultimate Trolley to go UDG Ultimate DIGI Trolley to go				
	1 Set package spare part on section right	Rivet and Washer A short	Rivet and Washer B medium	Rivet and Washer C long
UDG Ultimate Trolley to go UDG Ultimate DIGI Trolley to go				

Casing assembly instruction

UDG Ultimate Trolley to go
UDG Ultimate DIGI Trolley to go

UDG Ultimate Slingbag Trolley Deluxe
UDG Ultimate Slingbag Trolley set Deluxe

We recommend that you have your trolley frame, wheels and/or casing replaced at a luggage repair facility

RIGHT SIDE REMOVAL WHEEL CASING

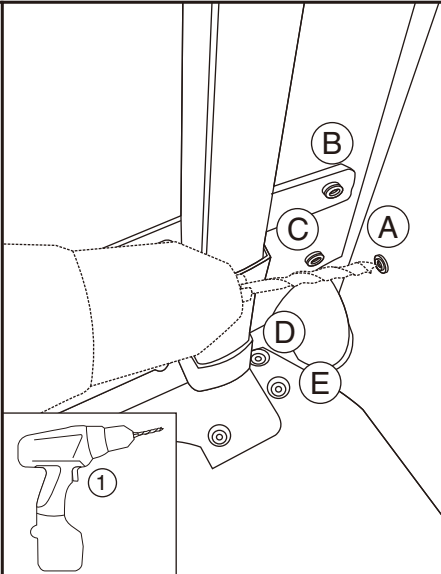

Drill the rivet (A) (B) (C) (D) (E) through from inside the bag using tool (1)

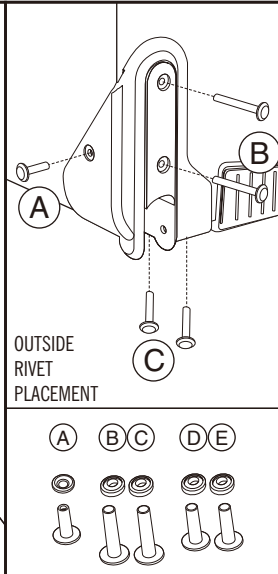

OUTSIDE RIVET PLACEMENT

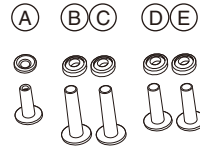

Put the rivet (A) (B) (C) through from inside the bag

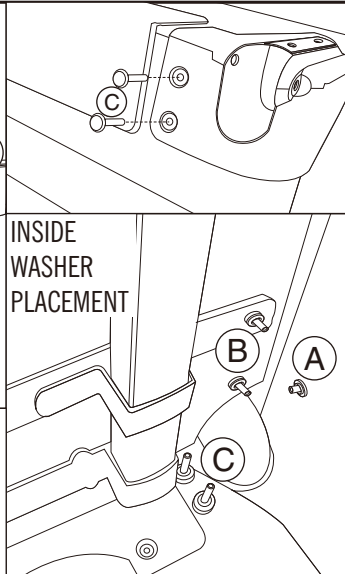

INSIDE WASHER PLACEMENT

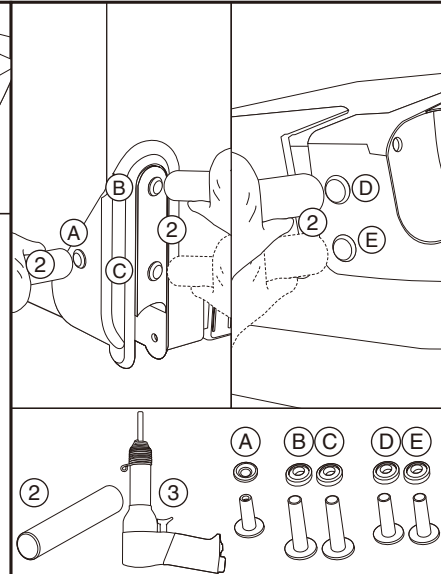

- Hold the outside (A) (B) (C) (D) (E) rivet using tool (2)
- Inside rivets (A) (B) (C) (D) (E) punched using tool (3) until secure and tighten with (A) (B) (C) (D) (E) washer

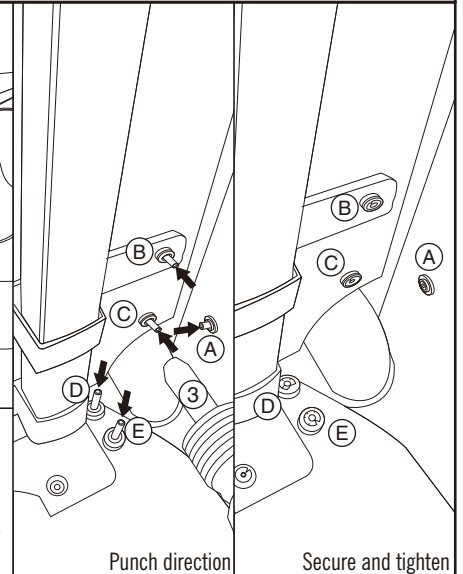

Punch direction Secure and tighten

LEFT SIDE REMOVAL WHEEL CASING

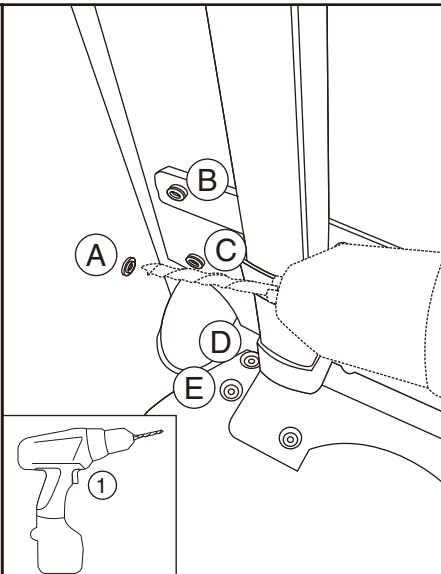

Drill the rivet (A) (B) (C) (D) (E) through from inside the bag using tool (1)

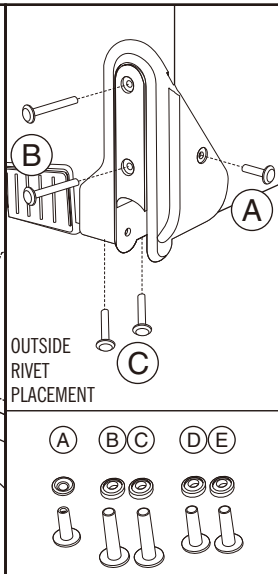

OUTSIDE RIVET PLACEMENT

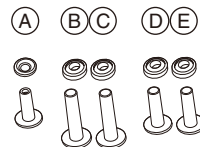

Put the rivet (A) (B) (C) through from inside the bag

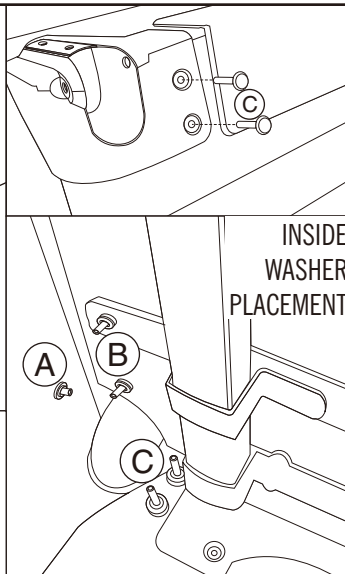

INSIDE WASHER PLACEMENT

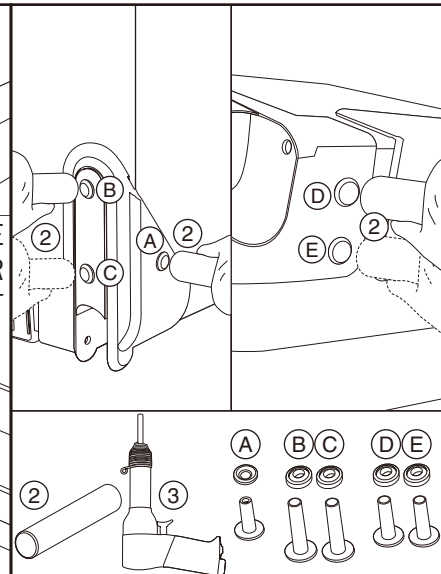

- Hold the outside (A) (B) (C) (D) (E) rivet using tool (2)
- Inside rivets (A) (B) (C) (D) (E) punched using tool (3) until secure and tighten with (A) (B) (C) (D) (E) washer

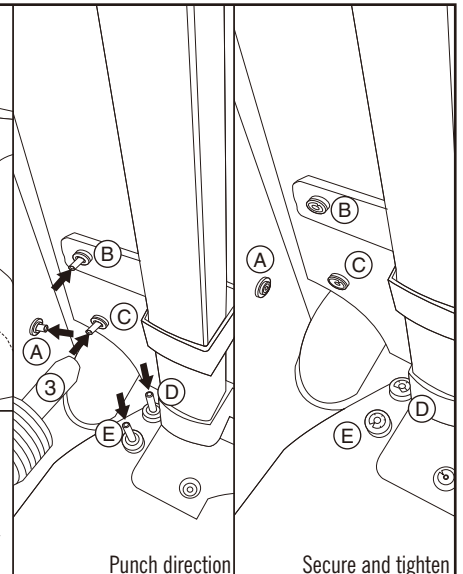

Punch direction Secure and tighten

Tools required

①

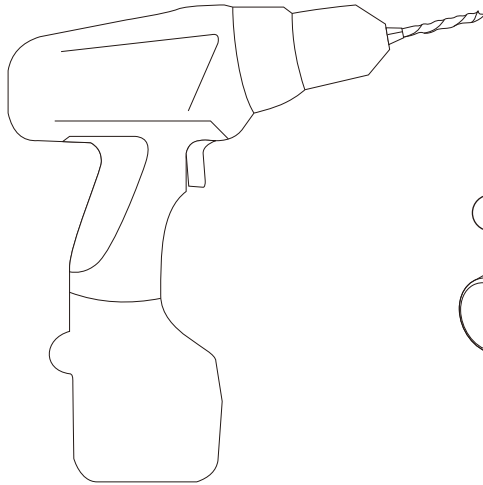

Portable electric drill

②

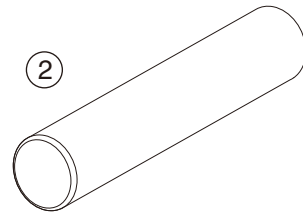

Metal pipe solid with \varnothing 10mm

③

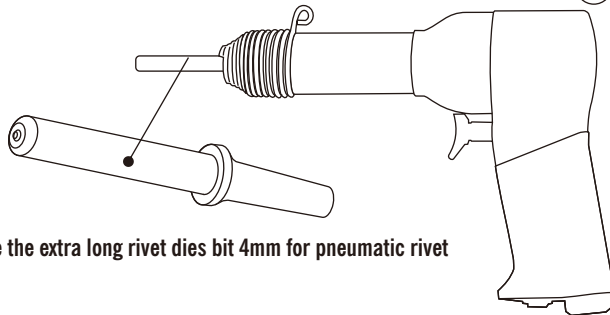

Use the extra long rivet dies bit 4mm for pneumatic rivet

Pneumatic rivet set with bucking bars

④

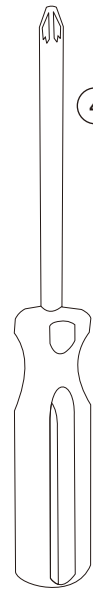

Screw driver

Parts details

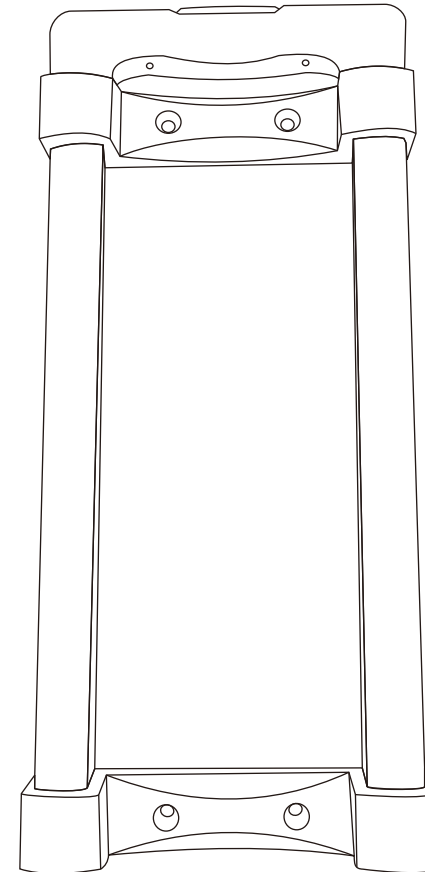

UDG frame trolley spare part

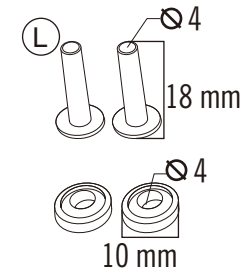

2 pcs UDG rivet and washer

1 set package spare part UDG Frame Trolley + 2 pcs rivet and washer

<p>Drill the rivet ① ② using tool ①</p>	<p>Remove the screw ① ② ③ ④ turning anticlockwise with tool ④</p>	<p>Remove the used frame trolley</p>	<p>Insert the new frame trolley</p>	<p>Put 2 pcs rivet through inside the bag at the rear on bag on mid. section of frame</p>

<p>Put 2 pcs washer on each rivet inside the bag</p>	<p>Hold on each rivet outside the bag using tool ②</p>	<p>Punch on each rivet inside the bag using tool ③</p>	<p>Check on each rivet inside the bag until secure and tighten.</p>	<p>Tighten the screw ① ② ③ ④ turn clockwise with tool ④ make it secure and tight</p>

Wheels assembly instruction

UDG Ultimate Trolley To Go UDG Ultimate SlingBag Trolley Deluxe
UDG Ultimate DIGI Trolley To Go UDG Ultimate SlingBag Trolley Set Deluxe

We recommend that you have your trolley frame, wheels and/or casing replaced at a luggage repair facility

1 Prepare a wrench, hex wrench and new wheels set.

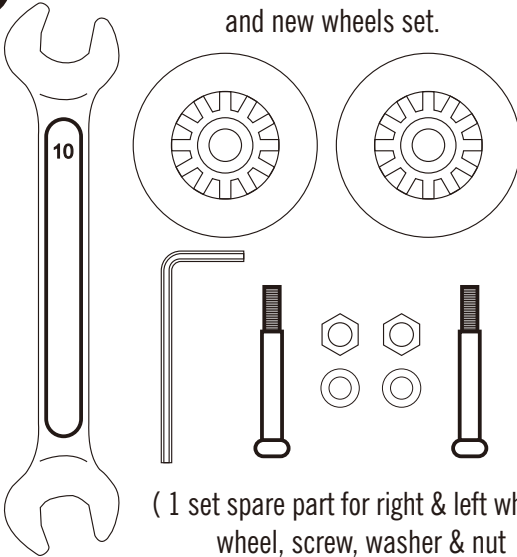

(1 set spare part for right & left wheel)
wheel, screw, washer & nut

2

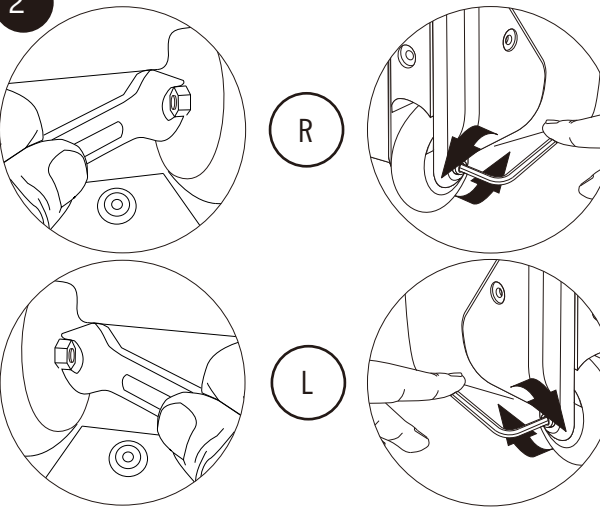

Turning anticlockwise the right wheel and turning clockwise the left wheel for loosen the screw

3

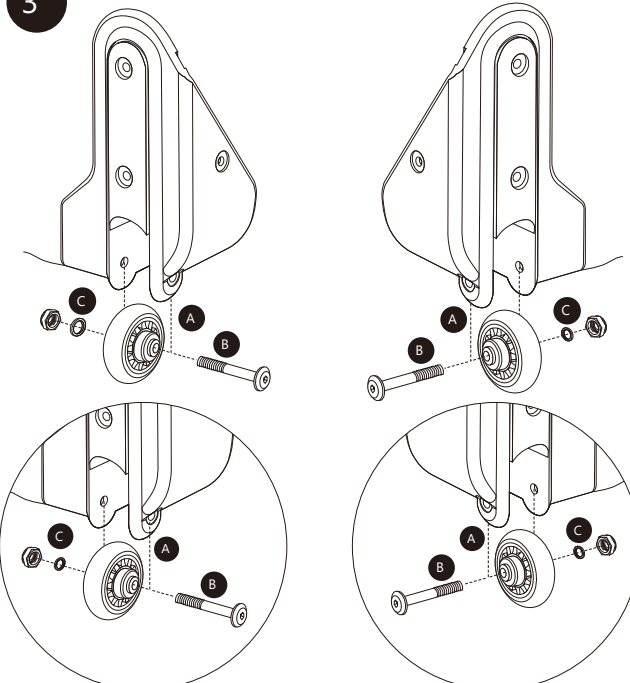

- A** Put the wheel into the frame.
- B** Install the screw into the hole between frame & bearings.
- C** Install the nut into the screw inside the bag.
- D** Tighten up the new wheel with hex key & wrench.

4

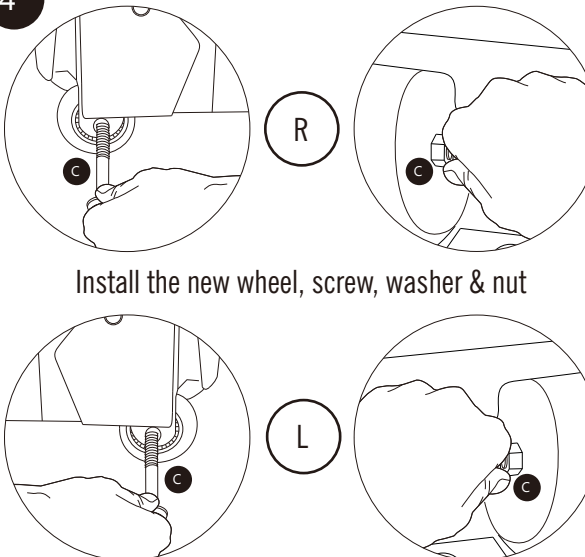

Install the new wheel, screw, washer & nut

5

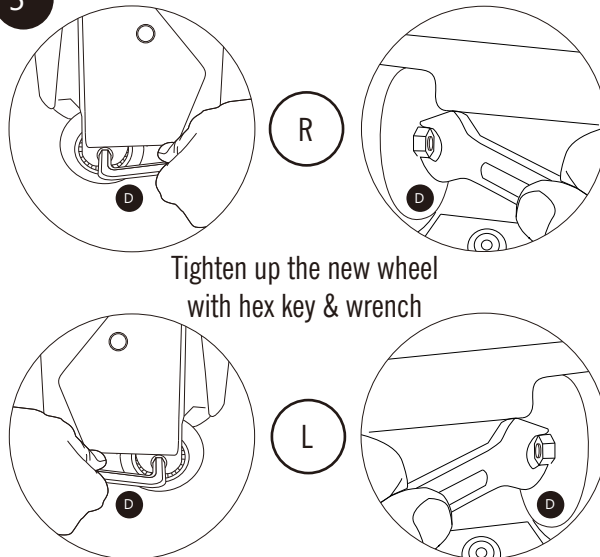

Tighten up the new wheel with hex key & wrench